

www.xzzx.com.cn

XCT80 汽车起重机 XCT80 TRUCK CRANE

服务热线 Service Tel : 400-110-9999

本印刷品不属于合同。出于产品不断改进的需要，我们保留对产品型号、参数、配置进行变更的权利，恕不另行通知。图片仅供参考，具体产品以实物为准。图片中得产品可能并非标准配置，部分部件可能需要另行购置。办理牌照和上路行驶需遵守当地法规。



徐州重型机械有限公司
XUZHOU HEAVY MACHINERY CO.,LTD.

地址：中国江苏徐州市铜山路165号 邮编(Post Code): 221004

Add: No.165 Tongshan Road Xuzhou Jiangsu China

电话(Tel): 0516-83462242 83462350

传真(Fax): 0516-83461669

服务电话(Service Tel): 0516-83461183

服务传真(Service Fax): 0516-83461180

质量监督电话(Quality Inquiry Tel): 0516-87888268

备件电话(Spare Parts Tel): 0516-83461542

请垂询
CONTACT



XCT80 汽车起重机 XCT80 TRUCK CRANE



徐州重型机械有限公司

XUZHOU HEAVY MACHINERY CO.,LTD.

K型支腿布置

提升支腿跨距 全回转作业 安全稳定

自组合式平衡重

增强工况拓展能力 实现自拆装 便捷高效



担大任行大道成大器

产品优势 PRODUCT ADVANTAGES

1 性能优越

- 采用五节 U 型主起重臂，起重性能强，领先于同行业相同吨位产品。四桥专用汽车底盘，配置 10 档变速箱，全桥悬挂，行驶性能优越，通过性和机动性强。



2 高效率作业

- 双独立卷扬设计，主、副卷可独立工作，索具采用快插袋式绳头，倍率更换更加方便，作业效率高；自拆卸组合式平衡重，采用液压油缸挂接，回转和配重挂接配有遥控盒操控，方便不同工况更换。

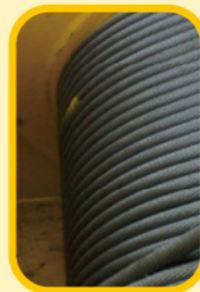
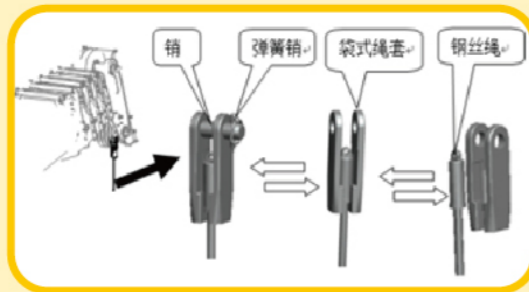

3 全新动力匹配

- 以低速大扭矩发动机为核心，结合带有超速档的大速比变速箱，兼顾车辆低速爬坡性能和高速转场性能，实现了高动力性与低油耗的完美融合；发动机有潍柴、重汽两种配置可供选择。

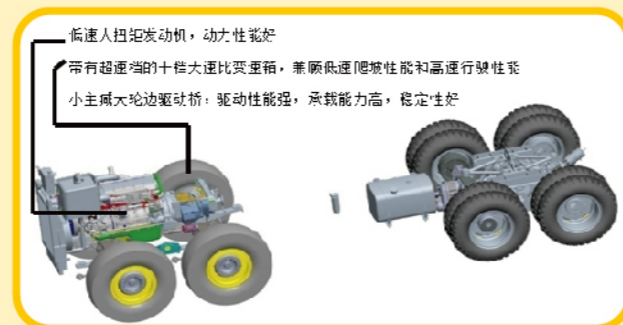

4 稳定K型支腿

- 采用前摆腿后伸缩 K 型支腿布置，有效提升支腿跨距，不需要前方第五支腿可实现 360°全回转作业，作业稳定性好。



5 操纵平稳

- 采用高性能液控负载敏感主阀，节流开口线性梯度更平滑，流量控制精确，操作平顺，微动性好；独特结构的回转缓冲技术运用，使回转系统操作平稳、无抖动。

6 全方位安全防护

- 前桥采用气压盘式制动，制动平稳、可靠，行驶更加安全；采用力限器多工况实时监控，配有高度限位、过卷防护装置，并设有组合操控，防止误操作，操纵更安全。

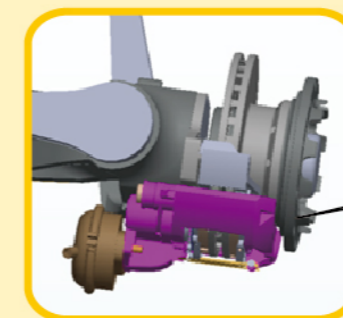

盘式制动，平稳可靠

7 人性化设计

- 专业团队打造全新外观造型，整机外观新颖流畅；采用全头豪华驾驶室，驾驶空间宽敞，完善的整车进出通道，推拉门操纵室，气动脚踏板设计，方便操作人员上、下，并配备独立冷暖空调，立体风道设计，操作环境更加舒适。

技术参数 TECHNICAL SPECIFICATIONS

XCT80

尺寸参数 Dimensions	Unit	
整机全长 Overall length	mm	14770
整机全宽 Overall width	mm	2800
整机全高 Overall height	mm	3890
重量参数 Weight		
行驶状态整机自重 Dead weight in travel state	kg	49870
前轴轴荷 Front axle load	kg	24000
后轴轴荷 Rear axle load	kg	26000
动力参数 Power		
发动机型号 Engine model		WP12.375N MC11.39-30
发动机额定功率 Engine rated output	kw/(r/min)	276/1900 290/1900
发动机额定扭矩 Engine rated torque	N.m/(r/min)	1800/(1000~1400) 1900/(1000~1400)
行驶参数 Travel		
最高行驶速度 Max.travel speed	km/h	80
最小转弯直径 Min.turning diameter	m	24
最小离地间隙 Min.ground clearance	mm	371
接近角 Approach angle	°	17
离去角 Departure angle	°	15.5
最大爬坡能力 Max.gradeability	%	40
百公里油耗 Fuel consumption of per 100km	L	≤45
主要性能参数 Lifting performance		
最大额定总起重量 Max.total rated lifting load	t	80
最小额定幅度 Min.rated working radius	m	3
转台尾部回转半径 Turning radius at swing table tail	mm	4670
基本臂最大起重力矩 Base boom max.load moment	kN.m	3000
基本臂 Base boom	m	12.4
最长主臂 Full-extend boom	m	47.5
最长主臂+副臂 Full-extend boom+Jib	m	65
纵向支腿距离 Outrigger longitudinal distance span	m	8.075
横向支腿距离 Outrigger lateral distance span	m	7.9
工作速度 Working speed		
起重臂起臂时间 Boom elevating time	s	70
起重臂全伸时间 Boom telescoping time	s	150
最大回转速度 Max.slewing speed	r/min	≤1.9
主起升机构最大速度(空载) Main winch max. speed(no load)	m/min	130
副起升机构最大速度(空载) Auxiliary winch max. speed(no load)	m/min	110

起重性能表 TOTAL RATED LIFTING LOAD

XCT80

XCT80主臂起重性能表(支腿全伸7.9m) Total rated lifting load for boom(Full-extend outrigger 7.9m)

支腿全伸7.9m, 11.5t平衡重
Full-extend outrigger7.9m counter weight 11.5t

工作幅度 Working radius (m)	基本臂 Base boom 12.4m			中长臂 Mid-extend boom 16.79m			中长臂 Mid-extend boom 21.17m			中长臂 Mid-extend boom 25.56m			中长臂 Mid-extend boom 29.95m			中长臂 Mid-extend boom 34.34m			中长臂 Mid-extend boom 38.72m			中长臂 Mid-extend boom 43.11m			全伸臂 Full-extend boom 47.5m		
	起重量 Lifting Load (kg)	主臂仰角 Boom angle (°)	起升高度 Lifting Height (m)	起重量 Lifting Load (kg)	主臂仰角 Boom angle (°)	起升高度 Lifting Height (m)	起重量 Lifting Load (kg)	主臂仰角 Boom angle (°)	起升高度 Lifting Height (m)	起重量 Lifting Load (kg)	主臂仰角 Boom angle (°)	起升高度 Lifting Height (m)	起重量 Lifting Load (kg)	主臂仰角 Boom angle (°)	起升高度 Lifting Height (m)	起重量 Lifting Load (kg)	主臂仰角 Boom angle (°)	起升高度 Lifting Height (m)	起重量 Lifting Load (kg)	主臂仰角 Boom angle (°)	起升高度 Lifting Height (m)	起重量 Lifting Load (kg)	主臂仰角 Boom angle (°)	起升高度 Lifting Height (m)	起重量 Lifting Load (kg)	主臂仰角 Boom angle (°)	起升高度 Lifting Height (m)
3.0	80000	67.8	12.8	65000	74.4	17.5																					
3.5	75000	65.2	12.5	63000	72.6	17.3	45000	77.0	22.0																		
4.0	68000	62.5	12.2	61000	70.7	17.1	45000	75.3	21.8																		
5.0	58000	56.9	11.5	54000	67.0	16.7	43000	72.5	21.5	38000	76.1	26.1	32000	78.7	30.7												
6.0	51000	50.8	10.7	47000	63.1	16.1	38000	69.5	21.0	35000	73.7	25.8	30000	76.7	30.4	24500	78.9	35.0									
7.0	43500	44.1	9.6	42000	59.0	15.5	34500	66.6	20.6	32000	71.3	25.4	28000	74.7	30.1	22500	77.2	34.7									
8.0	37000	36.2	8.2	36800	54.8	14.7	31600	63.5	20.0	28000	68.9	25.0	25500	72.6	29.7	20000	75.4	34.4	17900	77.6	39						
9.0	30500	25.9	6.2	29900	50.2	13.9	28200	60.3	19.4	26500	66.4	24.5	23800	70.6	29.3	18900	73.7	34.0	16900	76.1	38.7						
10.0				24300	45.3	12.8	24000	57.0	18.7	23700	63.9	23.9	21800	68.5	28.9	17700	71.9	33.7	15700	74.5	38.3	13400	76.6	43.0	12500	78.3	47.5
12.0				17100	33.7	10.0	16900	50.0	17.0	17900	58.6	22.7	18600	64.2	27.9	16600	68.2	32.8	14900	71.4	37.2	13000	73.8	42.3	11000	75.8	47.0
14.0							12400	42.0	14.9	13300	52.9	21.1	14000	59.7	26.6	14500	64.5	31.8	12700	68.1	36.6	11000	71.0	41.5	10000	73.3	46.3
16.0							9300	32.2	11.9	10300	46.7	19.3	10900	55.0	25.2	11400	60.6	30.6	11000	64.8	35.7	9500	68.1	40.6	9000	70.7	45.5
18.0										8000	39.8	16.9	8700	49.9	23.5	9100	56.6	29.2	9500	61.4	34.5	8400	65.1	39.6	8000	68.0	44.6
20.0										7000	44.4	32.4	7400	52.3	27.6	7700	57.8	33.2	7300	62.0	38.5	7200	65.3	43.3			
22.0													5600	38.2	18.8	6000	47.7	25.7	6200	54.1	31.6	6400	58.9	37.1	6400	62.5	42.4
24.0																5000	42.7	23.5	5200	50.1	29.9	5300	55.6	35.7	5400	59.7	41.1
26.0																4100	37.1	20.8	4300	45.9	27.8	4500	52.1	34.0	4700	56.7	39.7
28.0																3200	30.5	17.3	3400	41.3	25.5	3700	48.4	32.1	3900	53.6	38.1
30.0																			2900	36.2	22.6	3100	44.5	30.0	3300	50.4	36.3
32.0																						2600	40.3	27.5	2800	47.0	34.3
34.0																						2100	35.6	24.5	2300	43.4	32.0
36.0																									1800	39.4	29.4
倍率 Parts of line	12			10			8			6			6			5			4			3			2		

XCT80副臂起重性能表(全伸支腿7.9m) Total rated lifting load for jib(Full-extend outrigger 7.9m)

支腿全伸7.9m, 11.5t平衡重
Full-extend outrigger7.9m counter weight 11.5t

主臂长度 Boom 47.5m, 副臂长度 Jib 10.5m 主臂长度 Boom 47.5m, 副臂长度 Jib 17.5m

主臂仰角 Boom angle (°)	副臂安装角 Jib offset					
	0°	15°	30°	0°	15°	30°
	起重量 Lifting Load (kg)	起重量 Lifting Load (kg)	起重量 Lifting Load (kg)	起重量 Lifting Load (kg)	起重量 Lifting Load (kg)	起重量 Lifting Load (kg)
78	6300	4400	4200	3700	2000	1600
75	5800	4000	3700	3200	1600	1400
72	5100	3700	3500	2700	1400	1300
70	4700	3500	3400	2500	1300	1300
65	3900	3200	3000	1900	1200	1100
60	2800	2600	2500	1700	1100	1100
55	2100	1900	1800	1400	1000	900
50	1200	1100	1100	1100		
吊钩重量 Weight of hook block	250kg					

- 表中额定总起重量所表示的数值, 是在平整的坚固地面上本起重机能够保证的最大起重量。
- 表中额定总起重量包括吊钩和吊具的重量。
- Total rated loads shown in the tables means the max.load capacity crane can ensure when crane is set on flat and firm ground.
- Each total rated load in thr tables inclues weight of the hook and slings.